



# Crossyoke-Plansifter



3

RÜTER  
MASCHINEN

Crossyoke-Plansifter

RÜTER  
MASCHINEN

Plancher

# Crossyoke-Plansifter

On account of its flexible sieve stack the Crossyoke-Plansifter is suitable for a wide range of applications. It is ideal for...

- small mills with up to twelve sieve passages per plansifter.
- large mills with a capacity at the 1st break of up to 5 tonnes/h per sieve stack.
- control-sifting with a capacity of up to 100 tonnes/h.

Other fields of application include the sifting of maize and rice, starch and protein, mixed fodder, pellets, wood and cellulose, cork, spices, plastics, and other products.

Its special drive design and balancing principles bring about a saving of both weight and energy. Furthermore, no essential dynamic forces are transmitted to the building. Owing to the extensive use of light metals, a novel sieve construction system, and the application of modern design methods the Crossyoke Plansifter is about one-fifth the weight of conventional-type plansifters.

The add-a-unit design concept combined with its compact dimensions facilitates short assembly times, and the accommodation of unfavourable room dimensions. In its dismantled state the heaviest component weighs approx. 50 kg. The required minimum dimensions for the assembly space opening are 0.8 x 1.0 m.

High Performance · Compact · Flexible

Fast Assembly · Low Weight · Self-Balancing

Energy Saving · Optimal Product Carbon Footprint (PCF)

Flour Mills · Rebolting · Corn & Rice Milling

Starch & Protein · Petfood · Pellets · Biofuels

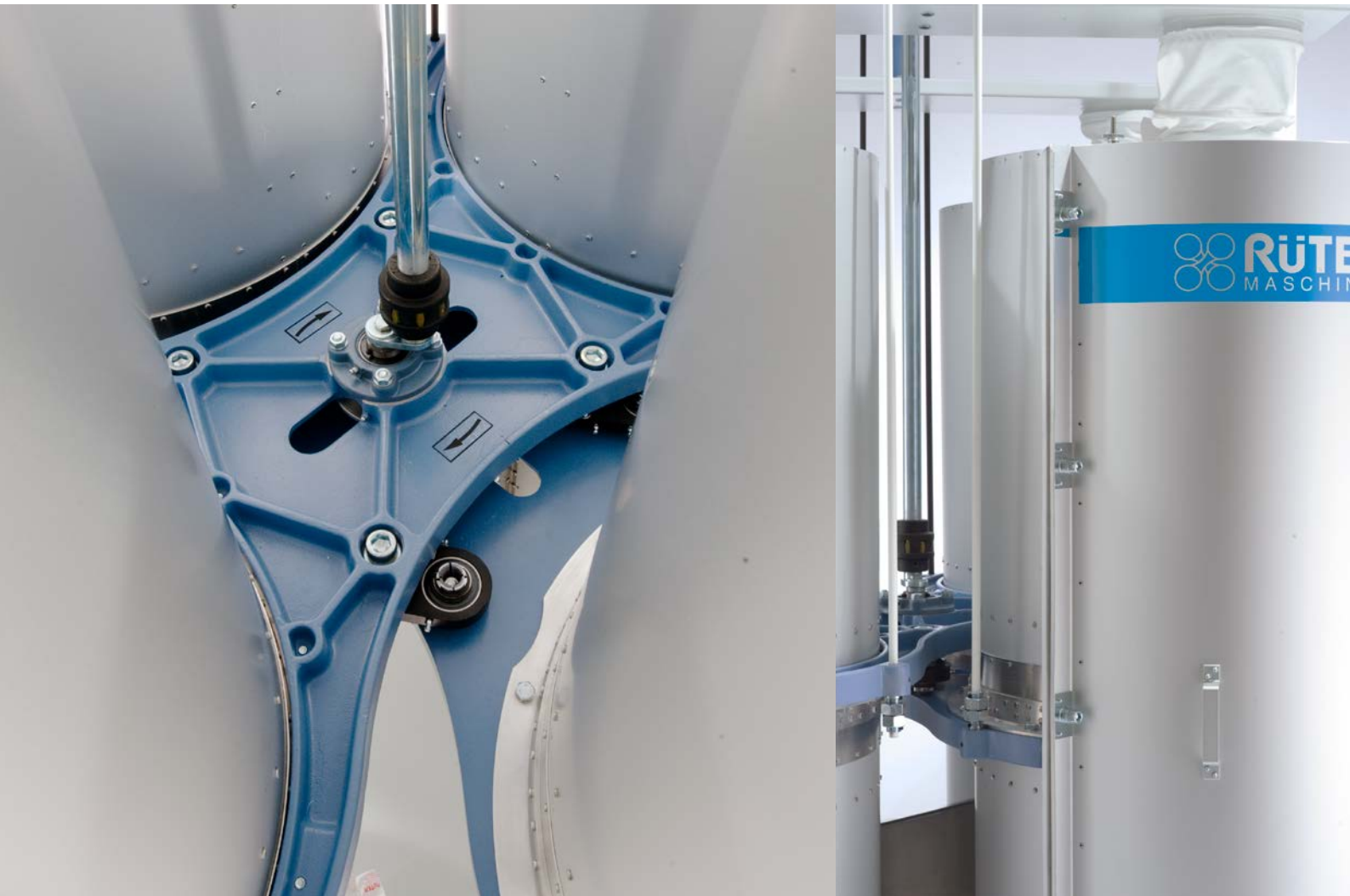

## Drive

A novel drive system enables the smooth, vibration-proof running action of the Crossyoke Plansifter.

In each machine two diagonally opposed sieve stacks are connected to one another by means of a yoke so as to form two plansifter units. These two yokes are joined at the area of intersection by four double-bearings to absorb centrifugal forces, with the two units balancing one another with a circular oscillating motion. This design reduces the drive shaft's power requirement to only 1.5 to 2.2 kW



## Aluminium sieve stack

Each sieve compartment consists of a cylindrical, two-piece housing containing square sieve frames. Four or 12 product channels are located between the housing and the sieve stack, allowing for a highly variable sifting scheme.

All sieves can be connected in series inside one sieve stack so as to attain optimum separation of fractions. In addition, for high output capacity, all sieves can be supplied simultaneously with the product to be sifted on parallel lines. Any conceivable combination of parallel and serial arrangements of sieves in the stack can be accommodated. Moreover, the sieve stack can be divided horizontally into 3 passages.

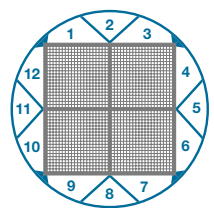
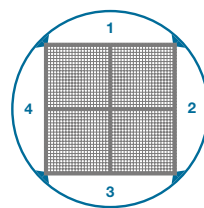



## Sieve

The sieve on the Crossyoke Plansifter is distinguished by its simple straightforward design, consisting of a sieve frame and sieve collecting bottom made from extruded aluminium sections. Strategically positioned feeder plates that project into the product channels direct the product to the desired sieve.

The sieves are resistant to wear and high temperatures.

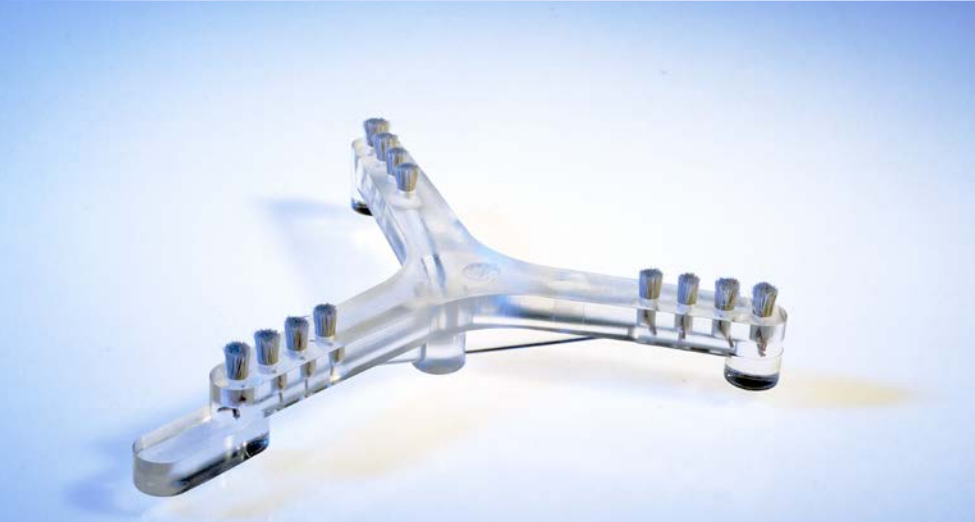
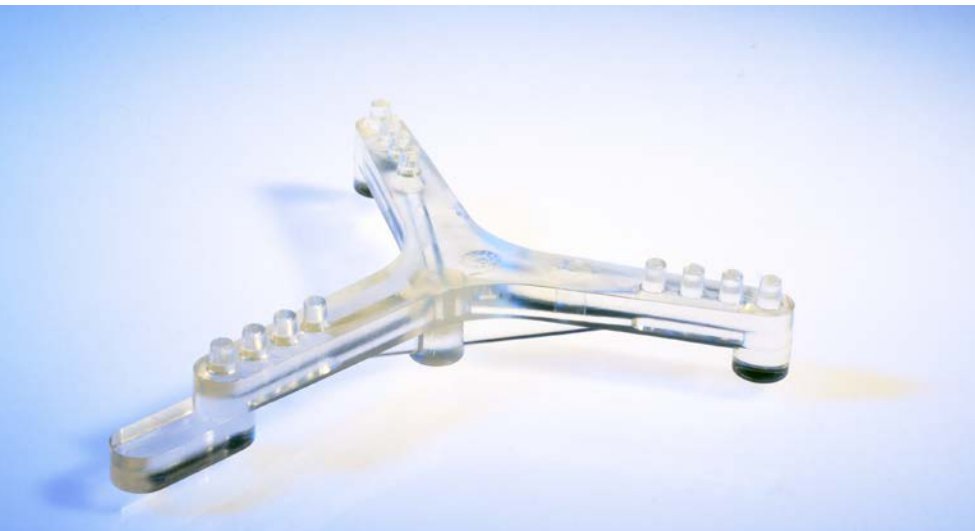

## Sieve cleaner

The patented sieve cleaner serves to increase the specific performance of the sieve area. Its innovative design combines both bottom cleaners and sieve cleaners into a simple component, thereby eliminating the need for an intermediate corrugated screen. It is manufactured from durable plastic material to ensure a long service life.

Top picture: version fitted with plastic naps,  
Bottom picture: version fitted with brushes.

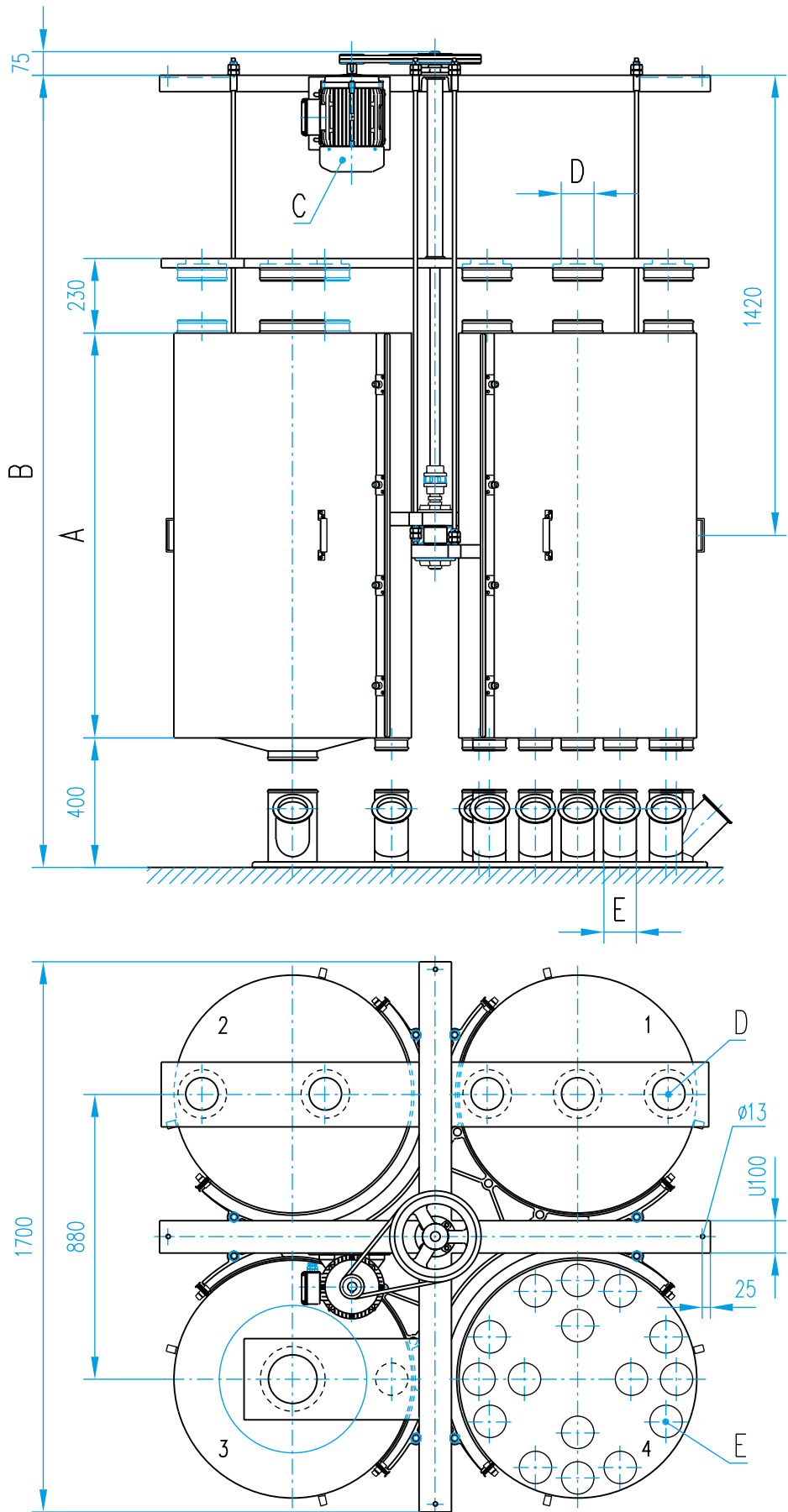



# Technical Data

## Measurements and weights

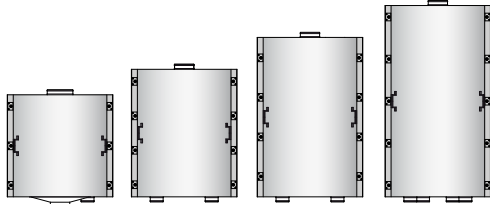
Sieve stack height	A	mm	500	600	800	1000	1250	1500
Sieves per sieve stack (Gross sieving area m <sup>2</sup> )			8	10	14	18	23	28
Total number of sieves			32	40	56	72	92	112
Net sieving area		m <sup>2</sup>	6.4	8.0	11.2	14.4	18.4	22.4
Machine height	B	mm	2070	2120	2220	2320	2445	2570
Driving power	C	kW	1.5	1.5	1.5	1.5	1.5	2.2
Inlet diameter	D	mm	100/150/200/250					
Outlet diameter	E	mm	100/150/200/250 (max. 11 of 12 possible positions)					
Weight		kg	350 – 700					
Fastening			4 pcs. screw M12					
Examples of heights of the sieve-stack housing								

## Optional equipment

**Closed-loop speed control** with frequency converter and frequency generator to enable a pulsating speed.

**Weight measurement** with load cells for process control and monitoring.



**Pneumatic sieve stack clamping device** (Fig. above)

**Rotating tube distributor** to deliver the product evenly to the four sieve stacks. Currently there are 8 types:

	Inlet	Outlets
1	200 mm	4 x 100 mm
2	250 mm	4 x 150 mm
3	350 mm	4 x 200 mm
4	200 mm	3 x 100 mm
5	150 mm	2 x 100 mm
6	200 mm	2 x 150 mm
7	300 mm	2 x 200 mm
8	350 mm	8 x 120 mm

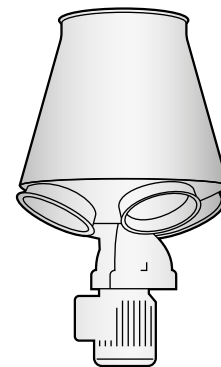

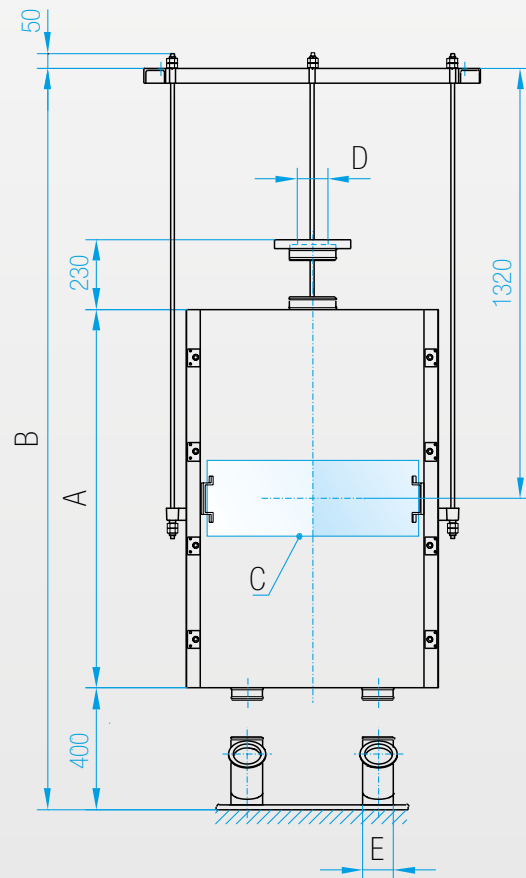

## Single-box Plansifter

The single-box plansifter is suitable for low capacity needs or when a limited number of passages are required. The sieve stack housing, the sieve stack and the sieves correspond to those of the Crossyoke Plansifter. However, an encapsulated counterbalance driving unit is integrated into the sieve stack. The sieve stack housing is suspended from a holding angle by means of three glass fiber bars. A supporting frame for assembly from either floor or ceiling can be supplied upon request.

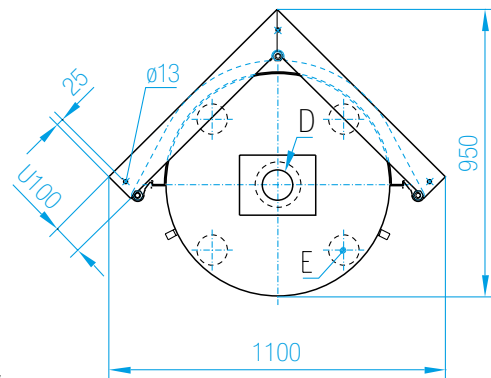

### Measurements and weights

Sieve stack height	A	mm	800	1000	1250	1500
Number of sieves			8	12	16	22
Net sieving area		m <sup>2</sup>	1.6	2.4	3.2	4.4
Machine height	B	mm	2120	2220	2345	2470
Driving power	C	kW	0.55			
Inlet diameter	D	mm	100/150/200/250			
Outlet diameter	E	mm	100/150/200/250 (max. 11 of 12 possible positions)			
Weight		kg	160 – 220			
Fastening			3 pcs. screw M12			

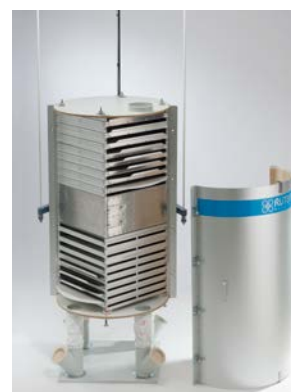

Sieve stack with encapsulated driving unit



**Rueter Maschinenbau** is a mechanical engineering firm of approximately twenty employees, located in N.W. Germany. A combination of a highly skilled manufacturing work-force and an innovative design team has ensured Rueter's reputation as Germany's leading manufacturer of small-scale equipment for the milling industry since 1988. Rueter's key product line consists of a series of highly efficient and compact plansifters of both single-box and crossyoke types.

An der Kapelle 27 · 32479 Hille-Nordhemmern · Germany  
Tel. +49 (0)5703-52029-0 · Fax +49 (0)5703-52029-29  
eMail: RueterMaschinen@t-online.de · www.RueterMaschinen.de



**Rueter Maschinenbau GmbH & Co. KG**

An der Kapelle 27 · 32479 Hille-Nordhemmern · Germany

Tel. +49 (0)5703-52029-0 · Fax +49 (0)5703-52029-29

eMail: [RueterMaschinen@t-online.de](mailto:RueterMaschinen@t-online.de) · [www.RueterMaschinen.de](http://www.RueterMaschinen.de)

